

City Commission Special Meeting Agenda  
Tuesday, December 9, 2025, 4:00 PM  
City Commission Chambers, 950 S. Grant Ave.

- Call to Order
- 1. Housing Grant Programs
  - a. First-Time Homebuyer Grant
  - b. Home Repair Program
  - c. Paint the Town Program
  - d. New Construction Incentive - Single-Family
  - e. New Construction Incentive - Multi-Family
  - f. Wastewater Improvement Waiver Program
  - g. Safe at Home Program
  - h. Sidewalk Install or Repair Program
  - i. Fence Program
- 2. Facade Grant Program
- 3. Loraine Street Improvements Discussion
- 4. Engineering Discussion
- 5. Airport Hangar Assessment Discussion
- 6. EOY Water Transfer
  - ADJOURNMENT



**CITY OF LIBERAL  
CITY COMMISSION MEETING  
December 9, 2025  
AGENDA ITEM # 1.**

To: Mayor Jose Lara  
Vice Mayor Matt Landry  
Commissioner Ron Warren  
Commissioner Janeth Vazquez  
Commissioner Jeff Parsons

Date: December 9, 2025

From: Keith Bridenstine, Building Services Director

RE: Housing Grant Programs

The Housing Grant Programs funded by the One Cent Sales Tax are presented for review and discussion. Minor clerical updates have been made to existing programs, and a new sidewalk program has been added to support the Comprehensive Plan. The programs will be presented at a future Commission meeting for approval.

**Recommendation:**

**CITY OF LIBERAL  
BUILDING PROGRAMS**

**FIRST-TIME HOMEBUYER GRANT**

- **\$3000 PER APPROVED APPLICANT**
- **MEET INCOME LIMITS – 125% OF MEDIAN INCOME**
- **HASN'T OWNED A HOME IN THE LAST 3 YEARS**

**HOME REPAIR PROGRAM**

- **WEATHERIZATION - \$3000 FOR WINDOWS, DOORS, INSULATION**
- **EXTERIOR ENHANCEMENT - \$3000**
- **EMERGENCY REPAIR - \$3000**
- **MEET INCOME LIMITS – 125% OF MEDIAN INCOME FOR SENIORS, VETS, OR DISABLED**
- **MEET INCOME LIMITS – 50% OF MEDIAN INCOME FOR VERY LOW APPLICANT**
- **HAVE TAXES PAID CURRENT**

**PAINT THE TOWN PROGRAM**

- **VOUCHER FOR \$500 TO PAINT EXTERIOR OF HOUSE, FENCE, SHED, ETC.**
- **TAXES MUST BE PAID CURRENT**
- **NO INCOME LIMITS**

**NEW CONSTRUCTION INCENTIVE – SINGLE FAMILY HOME**

- **\$7500 INCENTIVE FOR THE NEW CONSTRUCTION OF SINGLE-FAMILY HOME**
- **INCENTIVE TO OWNER OF PROPERTY BEING BUILT OR DEVELOPER OF A SPEC HOME**

**NEW CONSTRUCTION INCENTIVE – MULTI-FAMILY**

- **\$5000 INCENTIVE PER DOOR OF NEW MULTI-FAMILY CONSTRUCTION**
- **INCENTIVE TO OWNER OF PROPERTY BEING BUILT**

**WASTEWATER IMPROVEMENT WAIVER PROGRAM**

- **FEE OF \$10.00 CAN BE WAIVED FOR WATER BILL**
- **MUST BE 62 YEARS OF AGE OR OLDER**
- **BE UNDER 125% MEDIAN INCOME LIMITS**

**SAFE AT HOME PROGRAM**

- **FREE SMOKE AND CARBON MONOXIDE DETECTORS & NOAA RADIOS**
- **MUST BE FOR RESIDENCE OF APPLICANT ONLY (NO RENTALS)**

**SIDEWALK INSTALL OR REPAIR PROGRAM**

- **REIMBURSEMENT FOR INSTALLATION OR REPAIR OF SIDEWALK FOR RESIDENTIAL OR COMMERCIAL PROPERTIES.**
- **\$1500 CAP FOR RESIDENTIAL & \$2500 CAP FOR COMMERCIAL PROPERTIES.**

**FENCE PROGRAM**

- **\$3000 GRANT FOR REPAIR OR INSTALLATION OF FENCE TO CONTAIN ADOPTED DOG**
- **MUST ADOPT AND REGISTER A DOG FROM LIBERAL ANIMAL SHELTER**
- **BE UNDER 100% OF MEDIAN INCOME**



**CITY OF LIBERAL  
CITY COMMISSION MEETING  
December 9, 2025  
AGENDA ITEM # 1.a.**

To: Mayor Jose Lara  
Vice Mayor Matt Landry  
Commissioner Ron Warren  
Commissioner Janeth Vazquez  
Commissioner Jeff Parsons

Date: December 9, 2025

From: Keith Bridenstine, Building Services Director

RE: First-Time Homebuyer Grant

The First-time Homebuyer Grant helps individuals and families purchase their first home.

**Recommendation:**

**CITY OF LIBERAL  
FIRST TIME HOMEBUYER PROGRAM**

**What is the First Time Homebuyer Program?**

It is a soft second mortgage loan program to assist qualified low and moderate income individuals with the purchase of their first home. FTHB loan funds are to assist with down payment and/or closing costs.

APPLICATION MUST BE TURNED IN AT LEAST ONE MONTH  
PRIOR TO CLOSING THE MORTGAGE LOAN

**WHAT ARE THE MAXIMUM INCOME LIMITS AND FTHB LOAN AMOUNTS?**

Households earning at or below 125% of area median income are eligible for \$3,000 in assistance.

<b>Household Size</b>	<b>125% of Median</b>
1	\$72,375
2	\$82,750
3	\$93,125
4	\$103,375
5	\$111,750
6	\$120,000
7	\$128,250
8	\$136,500

**WHAT ARE THE TERMS OF THE SOFT SECOND MORTGAGE?**

The loan is a zero-interest, three year loan. The borrower will continue to own and occupy the structure for a period of three (3) years after the date on the Soft Mortgage.

The borrower will continue to maintain the property in a proper manner so as to prevent substantial destruction of the improvements due to the negligence of Applicant; and upon breach of any of the aforesaid covenants.

Homeowner is responsible only to pay back funds if the home is sold or destroyed in a 36-month period. The sliding scale of the Soft Loan Agreement is as follows:

Year	% of Amount of Soft Loan
1	25-36/36ths
2	13-24/36ths
3	1-12/36ths

### **ARE THERE ANY OTHER REQUIREMENTS?**

- Borrowers must take a City approved FTHB Counseling Workshop and provide Certificate of Completion prior to closing.
- All adults in the household must provide proof of income.
- Applications **MUST BE MADE** at least one month prior to closing the mortgage loan.
- Household size will be determined by parents and children in the household. Nieces, nephews and grandparents will not be allowed to show household size unless there is guardianship documentation provided.
- The home purchased under the FTHB program must be the borrower's principal place of residence; the property cannot be leased or rented during the term of the city loan.
- Persons with ownership of any real estate assets are not eligible.
- Funds are limited. Assistance is provided on a first-come, first-served basis, as long as funds remain available.
- Borrower must be a first-time homebuyer, which is a household that has not owned a home within the past three years. Borrowers must be able to qualify for a first mortgage from a mortgage lender.
- Homebuyers may purchase an existing single-family detached home, condominium, or townhouse located anywhere within the City of Liberal.

### **HOW TO CONTACT US:**

Erika Villa – Building Programs Coordinator  
City of Liberal - Building Department  
324 N. Kansas Avenue  
Liberal, KS 67901  
Phone: 620-626-2252  
Fax: 620-626-0572



**CITY OF LIBERAL  
CITY COMMISSION MEETING  
December 9, 2025  
AGENDA ITEM # 1.b.**

To: Mayor Jose Lara  
Vice Mayor Matt Landry  
Commissioner Ron Warren  
Commissioner Janeth Vazquez  
Commissioner Jeff Parsons

Date: December 9, 2025

From: Keith Bridenstine, Building Services Director

RE: Home Repair Program

The Home Repair Program helps senior citizens, families with disabilities, and veterans to repair a home they own and live in.

**Recommendation:**

## **CITY OF LIBERAL HOME REPAIR PROGRAM**

The City of Liberal Building Department is offering grants to senior citizens, veterans, or very low-income families for improvements to their home. The three grants available are Exterior Enhancement, Emergency Repair, and Weatherization for up to \$3000. Funding for the program is provided by the City of Liberal One-Cent Sales Tax. Grant funds are limited and applications will be provided on a first come first-serve basis.

### **ELIGIBLE REPAIRS**

- **Exterior Enhancement**
  - Exterior painting
  - Repair or replacement of existing fence
  - Roof repairs or replacement
  - Improvements to front yard landscaping
  - Driveway repair or replacement
  - Ramp
  
- **Emergency Repair & Replacement**
  - Mechanical/HVAC
  - Electrical
  - Plumbing
  - Structural Systems
  - Correct safety or health hazard
  - Drainage Improvements
  - Stove or Refrigerator if existing is unusable or unsafe
  
- **Weatherization**
  - Insulation for attic and walls
  - Weather-stripping for doors and windows
  - Exterior doors and storm doors
  - Window replacement
  - Lighting & Ventilation upgrade

## **ELIGIBILITY REQUIREMENTS**

- **Applying as a Senior Citizen**
  - 60 years of age or older
  - Combined household income must not exceed 125% of area median income.
  - Must be the owner and reside in the property
  - Property taxes must be paid to date.
  
- **Applying as a very low-income applicant**
  - Combined household income must not exceed 50% of area median income.
  - Must be the owner and reside in the property.
  - Property taxes must be paid to date
  
- **Applying as a Veteran**
  - Proof of Veteran – DD-214, Military ID, VHIC, DOD Card, DL or ID with a Veterans designation.
  - Combined household income must not exceed 125% of area median income.
  - Must be the owner and reside in the property
  - Property taxes must be paid to date.

## **TERMS AND CONDITIONS OF GRANT**

- Applicant must provide an estimate by a licensed & insured contractor.
- Work must be completed within 90 days of Letter of Approval. (extensions may be granted)
- Contractor should pull a no fee permit if it is necessary depending on the type of repair.
- Work must be inspected after completion.
- Upon completion and inspection an invoice will need to be provided and payment will be made to the contractor within 30 days.
- Applicant must reside in city limits or 3 the mile extraterritorial.

### **INCOME LIMITS**

The annual family income for very low income must be no more than 50% of the area median income:

<b>Household Size</b>	<b>50% of Median Income</b>
1	\$28,950
2	\$33,100
3	\$37,250
4	\$41,350
5	\$44,700
6	\$48,000
7	\$51,300

The annual family income for senior citizen or veteran must be no more than 125% of the area median income:

<b>Household Size</b>	<b>125% of Median Income</b>
1	\$72,375
2	\$82,750
3	\$93,125
4	\$103,375
5	\$111,750
6	\$120,000
7	\$128,250

### **HOW DO YOU APPLY?**

For more information and an application, please call the Building Programs Coordinator at (620) 626-2252 or come by City Hall. Grant funds are limited and applications will be provided on a first come first served basis. This program is financed through the City of Liberal One-Cent Sales Tax.

City of Liberal  
Building Department  
324 N. Kansas Avenue  
Liberal, KS 67901  
Phone: (620) 626-2250  
Fax: (620) 626-0572



**CITY OF LIBERAL  
CITY COMMISSION MEETING  
December 9, 2025  
AGENDA ITEM # 1.c.**

To: Mayor Jose Lara  
Vice Mayor Matt Landry  
Commissioner Ron Warren  
Commissioner Janeth Vazquez  
Commissioner Jeff Parsons

Date: December 9, 2025

From: Keith Bridenstine, Building Services Director

RE: Paint the Town Program

The Paint the Town Program provides citizens with free paint to beautify the exterior of their homes.

**Recommendation:**

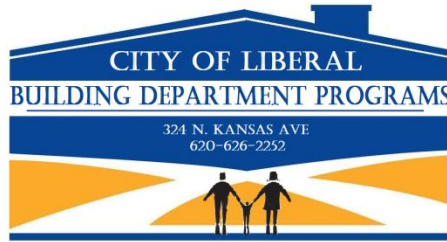

## **PAINT PROGRAM ELIGIBILITY GUIDELINES**

1. All applicants must be residents of the City of Liberal, KS.
2. All applicants must own and reside in the property to be painted.
3. All applicants must have property taxes paid current.
4. Vinyl siding qualifies; however, the homeowner must use special vinyl siding paint.
5. Applicants may not have received a voucher in the past 5 years.
6. Applicants may not owe the city any special assessments.
7. Trim, soffit, fascia, sheds, fences, decks and other outdoor amenities may qualify for the program, but must be specified at the time of the application.

### **APPROVED APPLICANTS MUST:**

- ❖ Abate all nuisance violations on the property. This includes but is not limited to unlicensed vehicles, trash, yard waste and debris. All nuisance violations that need to be abated and repairs that must be made to the house prior to painting will be noted.
- ❖ Make all repairs prior to receiving any paint or supplies. The owner scrapes, pressure washes and prepares the house for painting.
- ❖ Utilize voucher of \$500 to purchase paint and supplies within a week of the date of approval. The paint project should be completed within 60 days. Please contact the City if an extension is needed.
- ❖ If the painting project is not complete within the 60 days allowed, the applicant will then be responsible for reimbursing the City the total amount paid for paint and supplies
- ❖ City staff will do an onsite inspection of the property and will take BEFORE and AFTER pictures.
- ❖ Homeowner is responsible for any damages to property or adjacent properties.
- ❖ Only the supplies listed on the Paint Voucher will be approved. Any thing purchased that is not on the list will not be covered by the program.
- ❖ A voucher will be given to the applicant after receiving BEFORE pictures of the project to be painted. Also, send AFTER pictures of the completed project. Please email pictures to [erika.villa@cityofliberal.org](mailto:erika.villa@cityofliberal.org).

## Applicant Information

Name of Homeowner : \_\_\_\_\_

Home Address: \_\_\_\_\_ Liberal, Kansas 67901

Email: \_\_\_\_\_

Home Phone: (    ) \_\_\_\_\_ Work phone (    ) \_\_\_\_\_

- Please provide a copy of most current property tax receipt showing taxes are paid current.
- Specify what the paint will be used for, paint can only used for exterior purposes such as home exterior (siding, trim, soffit, fascia), sheds, fence, deck, or other outdoor amenities.

\_\_\_\_\_

- Have you applied for the paint before?     YES  NO

If YES, what was the year of your last application? \_\_\_\_\_

### **READ AND CAREFULLY CONSIDER THE FOLLOWING BEFORE SIGNING THIS APPLICATION:**

I hereby apply for assistance from the City of Liberal Paint and Caulk Program. I declare that I own and reside at the address listed above and it is not used as rental property.

I realize that my statements are subject to verification. I will report immediately, any changes in the information I have given. I declare that the information on this application is true, correct and complete to the best of my knowledge. I hereby grant permission to the City of Liberal to inspect the above referenced premise under the COL Paint & Caulk Program. The City of Liberal is not liable for any legal or financial claim stemmed by any damages. I understand I am responsible for any damages to my property or adjacent properties.

I HAVE READ AND UNDERSTAND THE GUIDELINES & EXPECTATIONS BY WHICH I MUST ABIDE AND I AGREE TO COMPLY WITH SAID GUIDELINES & EXPECTATIONS.

HOMEOWNER SIGNATURE: \_\_\_\_\_ DATE \_\_\_\_\_



**CITY OF LIBERAL  
CITY COMMISSION MEETING  
December 9, 2025  
AGENDA ITEM # 1.d.**

To: Mayor Jose Lara  
Vice Mayor Matt Landry  
Commissioner Ron Warren  
Commissioner Janeth Vazquez  
Commissioner Jeff Parsons

Date: December 9, 2025

From: Keith Bridenstine, Building Services Director

RE: New Construction Incentive - Single-Family

The New Construction Incentive allocates additional financial support for single-family home construction.

**Recommendation:**

## **New Construction Housing Incentive Program**

The City of Liberal, Kansas has identified the need and the actions surrounding housing issues within its bounds. The City of Liberal has identified the fact that economic issues related to the lack of housing has a large impact on the community. The New Construction Housing Incentive Program is intended to develop and expand the local economy by promoting and encouraging development projects that enhance the City's economic base and that may also diversify and expand job opportunities. The availability of quality housing stock encourages the relocation of businesses and attracts new business enterprises, as well as the expansion of existing business enterprises within the City, which in turn stimulates growth, creates jobs and increases property tax base and sales tax revenues. The promotion of the housing stock is a major contributing factor to the growth of the City, which in turn stimulates trade and commerce and reduces unemployment. Housing development will attract and encourage business relocation and expansion since business will look to the available housing stock to meet the needs of management and the work force. The well-being and economic growth of the Liberal community benefits all its citizens.

The City Commission hereby approves the policies and procedures related to the New Construction Housing Incentive Program which will provide a seven thousand five hundred-dollar (\$7,500) incentive per new single-family home built in Liberal and a five thousand-dollar (\$5000) incentive per unit for Multi-Family construction.

The program is subject to budget restrictions, available funding and yearly commission approval.

### **PROGRAM GUIDELINES**

Applicant must apply with the City of Liberal Building Department and complete a Form W-9.

Single-family Owner-occupied dwelling: The homeowner of any new single-family residence may apply for \$7,500 upon final inspection of the home when the property is finalized and ready for occupancy.

Multi-Family Dwelling: Developer may apply for \$5,000 per unit upon final inspection and the property is finalized and ready for occupancy.

Mobile homes may qualify, but must meet the following criteria:

- Owner applies for a permit and demolishes a mobile home more than 20 years old.
- Owner applies for permit to place a mobile home less than 5 years old back on the same location.

Proposed project must be located within Liberal's city limits.

Development and construction must comply with existing Zoning Regulations and Building Codes.

Funds are dispersed on a first come first serve basis until funds have been depleted.

The program is subject to budget restrictions, available funding and yearly commission approval.

#### **DEFINITIONS:**

***Dwelling, Single-family:*** *New construction or Residential Design Manufactured Homes, never before occupied or previously placed as a dwelling on a permanent foundation. No connected or common walls; must include purchase of lot. The developer/builder is under contract to produce a specific home for the property owners of the finished home.*

***Dwelling, Speculative Single-family:*** *A single-family home constructed with no formal commitment from the purchaser of the finished home. A speculative single-family home is contrast with a custom-built single-family home, where the developer/builder is under contract to produce a specific single-family home for the property owners of the finished home. The developer/builder is the original purchaser of the lot. A speculative single-family home may be sold prior to completion.*

***Dwelling, Multiple-Family:*** *A building having separate accommodations (Duplex, Triplex, etc.) for and occupied exclusively by more than one family. For the purpose of this incentive, the multiple-family dwelling must be constructed on a permanent foundation and not a mobile home.*

***Apartment:*** *A room or suite of rooms designed as a residence and generally located in a building occupied by more than one household. For the purpose of this incentive, the apartment must be constructed on a permanent foundation and not a mobile home.*

***Rental Property:*** *A property from which the owner receives payments from the occupants(s), known as tenants, in return for occupying or using the property. For the purpose of this incentive, the rental property must be on a permanent foundation and not a mobile hom*



**New Construction Housing Incentive Program  
Application**

Name of Applicant: \_\_\_\_\_

Address of Applicant: \_\_\_\_\_

Legal Description/Address of Property:  
\_\_\_\_\_

Anticipated Closing Date/or Speculative Home: \_\_\_\_\_

Final Inspection Date: \_\_\_\_\_

**New Construction Housing Incentive Program**

**I am applying as homeowner of the property** \_\_\_\_\_

**I am applying as developer of the property—this is a speculative home** \_\_\_\_\_

**I am applying as developer of the property—this is a multi-family dwelling** \_\_\_\_\_  
How many units will there be? \_\_\_\_\_

**Incentives and reimbursements will be made as long as budgeted funds are available.  
The program is subject to annual review by the City Commission.**

**I fully understand the City of Liberal’s New Construction Housing Incentive Program  
and agree to comply with the terms and conditions as specified in the program. I also  
understand it is my sole responsibility to provide the necessary documentation to the  
City of Liberal Housing Department for payment of incentives or reimbursements and  
that these will be paid as long as budgeted funds are available.**

**Signed:** \_\_\_\_\_

**Date:** \_\_\_\_\_

**Return Completed form to:**

**City of Liberal Building Dept.  
P.O. Box 2199  
Liberal, KS 67905-2199**

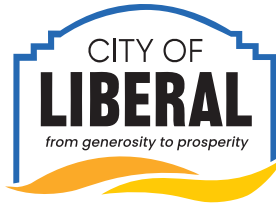

**CITY OF LIBERAL  
CITY COMMISSION MEETING  
December 9, 2025  
AGENDA ITEM # 1.e.**

To: Mayor Jose Lara  
Vice Mayor Matt Landry  
Commissioner Ron Warren  
Commissioner Janeth Vazquez  
Commissioner Jeff Parsons

Date: December 9, 2025

From: Keith Bridenstine, Building Services Director

RE: New Construction Incentive - Multi-Family

The New Construction Incentive — Multi-Family has the same guidelines and purpose as the prior single-family incentive, with a different amount.

**Recommendation:**



**CITY OF LIBERAL  
CITY COMMISSION MEETING  
December 9, 2025  
AGENDA ITEM # 1.f.**

To: Mayor Jose Lara  
Vice Mayor Matt Landry  
Commissioner Ron Warren  
Commissioner Janeth Vazquez  
Commissioner Jeff Parsons

Date: December 9, 2025

From: Keith Bridenstine, Building Services Director

RE: Wastewater Improvement Waiver Program

Last year, with the expiration of the Water Improvement Fee, the Wastewater Improvement Fee was created, and the waiver program was shifted to that fee. All citizens already receiving the water waiver were automatically enrolled in the wastewater waiver.

**Recommendation:**

## **WASTEWATER SYSTEM IMPROVEMENT FEE WAIVER PROGRAM**

### **What is the Wastewater System Improvement Fee Waiver Program?**

- The Wastewater System Improvement Fee of \$10.00 will be waived from your water bill if you qualify under the guidelines of the program.

### **What are the restrictions?**

#### **Meet ALL the following criteria:**

- You must be the occupant in your home located within the Liberal City limits and produce a water bill showing the account is in your name.
- Combined household income does not exceed 125% of median income.
- You must be a least 60 years of age or older on the day of the application or you must be disabled or have a disabled family member.

### **How do you qualify for the program?**

- Complete a short application
- Show a water bill in your name
- Show a photo ID
- Previous year Tax Return or Social Security reward letter required for verification of income.
- Produce proof of disability if applicable

### **How do you Apply?**

For more information and an application, please call the Building Programs Coordinator at 620-626-2252 or come into City Hall to apply.

City of Liberal  
Building Department  
324 N. Kansas Ave.  
Liberal, KS 67901  
620-626-2252



**CITY OF LIBERAL  
CITY COMMISSION MEETING  
December 9, 2025  
AGENDA ITEM # 1.g.**

To: Mayor Jose Lara  
Vice Mayor Matt Landry  
Commissioner Ron Warren  
Commissioner Janeth Vazquez  
Commissioner Jeff Parsons

Date: December 9, 2025

From: Keith Bridenstine, Building Services Director

RE: Safe at Home Program

The Safe at Home Program provides free smoke detectors, carbon monoxide detectors, and NOAA weather radios to citizens.

**Recommendation:**



SAFE AT HOME PROGRAM APPLICATION

Please read and complete BOTH SIDES of this application. This application and waiver must be completed and SIGNED before approval of application.

NAME: \_\_\_\_\_

ADDRESS: \_\_\_\_\_ LIBERAL, KS 67901

HOME PHONE/DAYTIME PHONE: \_\_\_\_\_

HOW MANY STORIES DOES YOUR HOME HAVE? \_\_\_\_\_

DO YOU HAVE A BASEMENT? YES \_\_\_ NO \_\_\_

WHAT TYPE OF DETECTOR ARE YOU APPLYING FOR?

\_\_\_\_\_ SMOKE DETECTOR

\_\_\_\_\_ CARBON MONOXIDE DETECTOR

\_\_\_\_\_ NOAA RADIO

HOW DID YOU HEAR ABOUT THIS PROGRAM? \_\_\_\_\_

SIGNATURE: \_\_\_\_\_ DATE: \_\_\_\_\_

Please Return Application To: Erika Villa, Housing Programs Coordinator  
City of Liberal Building Dept  
324 N Kansas Ave  
P.O. Box 2199  
Liberal, KS 67905-2199

\*\*\*\*\*

OFFICE USE ONLY

Date received: \_\_\_\_\_ Authorized by: \_\_\_\_\_

WAIVER AND RELEASE OF ALL CLAIMS

For and in consideration of my/our participation in the City of Liberal SAFE at HOME Program, I/we agree to release the City of Liberal, its agents and employees, its Housing Department and Fire Departments, from all claims, demands, suits, and causes of action, of every nature whatsoever, on account of damage, personal bodily injuries, or death. resulting from the installation, failure to operate or faulty operation of the carbon monoxide and/or smoke detector received from the City of Liberal.

By signing this release, I/we accept the carbon monoxide detection device and agree to install it as instructed. The undersigned further acknowledges that the City of Liberal and its agents or employees, expressly disclaim any liability for damage resulting from the installation of this carbon monoxide and/or smoke detection device, and I/we hereby release the City of Liberal and its agents and employees from any and all claims and/or damages resulting therefrom.

My/our signature(s) appearing below indicate that I/we understand the above and intend to be legally bound.

\_\_\_\_\_  
Owner/Occupant

\_\_\_\_\_  
Owner/Occupant

\_\_\_\_\_  
Street Address

Date:\_\_\_\_\_



**CITY OF LIBERAL  
CITY COMMISSION MEETING  
December 9, 2025  
AGENDA ITEM # 1.h.**

To: Mayor Jose Lara  
Vice Mayor Matt Landry  
Commissioner Ron Warren  
Commissioner Janeth Vazquez  
Commissioner Jeff Parsons

Date: December 9, 2025

From: Keith Bridenstine, Building Services Director

RE: Sidewalk Install or Repair Program

The Sidewalk Install or Repair Program is a new staff-created program to help advance the vision of the recently adopted Comprehensive Plan. This program would provide incentives for better sidewalks and pedestrian access throughout the City.

**Recommendation:**

## **CITY OF LIBERAL SIDEWALK INSTALL OR REPAIR PROGRAM**

### **PURPOSE**

In an effort to follow the comprehensive plan and improve the walkability and pedestrian safety throughout the City of Liberal this program is meant to improve quality of life and lower cost impacts to the citizens.

### **COST ASSISTANCE**

The Housing & Community Development department offers a cost share for a Sidewalk Infrastructure installation & repair program for residential and commercial properties within City limits. The Sidewalk Program can also be used to fill in areas where sidewalks do not exist between existing sidewalks. This program applies to sidewalks parallel to the right of way along the street. For residential properties there is a program cap of \$1500 per property. For commercial properties there is a program cap of \$2500 per property.

- Any residential or commercial property owner will be reimbursed \$1 per sq ft of sidewalk installed.
- Any residential or commercial property owner will be reimbursed \$2 per sq ft for any sidewalk extending an existing section sidewalk.
- Any residential or commercial property owner will be reimbursed \$3 per sq. ft. for any sidewalk along a route recognized by the comprehensive plan as a corridor improvement need.

### **QUALIFICATIONS**

The terms of the Sidewalk Program are as follows:

- Work must be completed by a licensed contractor.
- There are no income qualifications for this program.
- Property taxes shall be paid up to date.
- All work shall conform to applicable City of Liberal standards and regulations outlined in Chapter 13 Article 2 of the city code.
- Sidewalks will be a minimum of five feet (5') wide (unless specified by inspector).
- A Building Permit is required by the Building Department prior to construction. The permit will be at no cost to the owner.
- Pre-inspection of the job will be required by Building Department before any concrete is removed or placed.
- Concrete will be 4000 psi from a concrete company, no bag mix will be allowed.
- Property owner agrees to hold City of Liberal harmless for any damage to property due to work activity.
- Property owner is responsible for reseeding, re-sodding, repair/replacement of irrigation systems and/or other landscaping required due to the work.
- Property owner shall be responsible for prompt payment to contractor(s) and/or vendors.
- Curb and gutter construction, if needed, is the responsibility of the City. Preapproval is needed by the Building Department. The City may use the same contractor as the property owner, if such additional work is necessary.
- Following proof of completion, the City shall pay its share to the contractor or property owner who did the work.
- Work must be completed within 90 days of approval letter.
- Does not apply for new residential or commercial development.
- Funds are limited. First come first serve.

**Note:** Some restrictions may apply. To see if your sidewalk qualifies, please contact the **Building Department** at **620-626-2261** or in person at **324 N. Kansas Ave. Liberal, KS 67901**



**CITY OF LIBERAL  
CITY COMMISSION MEETING  
December 9, 2025  
AGENDA ITEM # 1.i.**

To: Mayor Jose Lara  
Vice Mayor Matt Landry  
Commissioner Ron Warren  
Commissioner Janeth Vazquez  
Commissioner Jeff Parsons

Date: December 9, 2025

From: Keith Bridenstine, Building Services Director

RE: Fence Program

The Fence Program, created last year, is intended to lower the number of stray animals, help incentivize citizens to adopt from the Liberal Animal Shelter, and beautify the City.

**Recommendation:**

**CITY OF LIBERAL  
FENCE PROGRAM**

The City of Liberal is offering grants to citizens who have adopted a dog from the shelter into their home. The grant is for the repair or installation of a fence to contain the pet in an amount to \$3000. Funding for the program is provided by the City of Liberal One-Cent Sales Tax. Grant funds are limited and applications will be provided on a first come first-serve basis.

**ELIGIBLE FENCES**

- Chain Link (with or without a concrete footer)
- Wooden Picket (with or without a concrete footer)
- Block or Brick

**ELIGIBILITY REQUIREMENTS**

- Must have adopted and registered a dog from the Liberal Animal Shelter.
- Combined household income must not exceed 100% of area median income.
- Must be the owner and reside in the property.
- Property taxes must be paid to date.

**TERMS AND CONDITIONS OF GRANT**

- Applicant must provide an estimate by a licensed & insured contractor.
- Work must be completed within 90 days of Letter of Approval. (extensions may be granted)
- Contractor must pull a no fee permit.
- Work must be inspected after completion.
- Upon completion and inspection an invoice will need to be provided and payment will be made to the contractor within 30 days.

**INCOME LIMITS**

The annual family income for the fence grant must be no more than 100% of the area median income:

<b>Household Size</b>	<b>100% of Median Income</b>
1	\$57,900
2	\$66,200
3	\$74,500
4	\$82,700
5	\$89,400
6	\$96,000
7	\$102,600
8	\$109,200

## **HOW DO YOU APPLY?**

For more information and an application, please call the Building Programs Coordinator at (620)626-2252 or come by City Hall. Grant funds are limited and applications will be provided on a first come first served basis. This program is financed through the City of Liberal One-Cent Sales Tax.

City of Liberal  
Building Department  
324 N. Kansas Avenue  
Liberal, KS 67901

Phone: (620) 626-2250

Fax: (620) 626-0572



**CITY OF LIBERAL  
CITY COMMISSION MEETING  
December 9, 2025  
AGENDA ITEM # 2.**

To: Mayor Jose Lara  
Vice Mayor Matt Landry  
Commissioner Ron Warren  
Commissioner Janeth Vazquez  
Commissioner Jeff Parsons

Date: December 9, 2025

From: Kristyn Reust, Finance Director

RE: Facade Grant Program

The Facade Grant Proposal for 2026 includes an addition to allow old signage to be taken down and replaced. The previous version did not allow signage to be a part of the program, but we believe it would be appropriate to allow as we have seen the significant difference updated signage brings to the business fronts.

**Recommendation:**



#### GUIDELINES FOR FAÇADE IMPROVEMENT GRANTS - CITY OF LIBERAL

1. The City of Liberal offers development assistance in the form of 50/50 matching grant money for commercial businesses and property owners located within the City of Liberal, Kansas. Residential, municipal, state, federal, not for profits and church properties are not eligible. Mixed-use buildings are eligible if the first floor is commercial in nature.
2. A maximum grant for a qualifying project is ten thousand dollars (\$10,000) and must be matched dollar for dollar by the building owner or business. Financial assistance is provided for permanent building and new site improvements, including old sign removal and replacement. Examples of permanent improvement include: Life safety and accessibility improvements required by code, parking lot, sidewalks, façade rehabilitation, and repair/replacement of windows or doors.
3. The business or building owner must match the City's grant with building improvements outside of the building.
4. Grants will be made on a "first come first served" basis and there are limited funds available each year.
5. Grants will be paid on a REIMBURSEMENT BASIS ONLY.
6. The project MUST be completed within 12 months of being approved to be reimbursed unless otherwise pre-planned with the Grant Director.
7. Proceeds of the façade grants shall not be used to: pay off or refinance existing debt, pay salaries or applicant's officers or employees, pay for the purchase or down payment for real estate, or pay income, real estate or other taxes or assessments.
8. The property will meet all applicable building, life safety, and zoning and maintenance codes upon project completion. The applicant must obtain required building permits and/or historic reviews prior to beginning any improvements.
9. At the time of application, there shall be no taxes, fees or other debts owed to the City by the applicant and/or building owner.
10. Only an individual or business having a legal interest in the subject property may make an application. This includes: a tenant, owner of the property, or an individual or entity holding a fully executed contract to purchase the subject property.
11. If the applicant does not own the property, but is a tenant of the property, the tenant must have the permission of the property owner in writing.
12. Application for grant assistance will be considered within 21 business days after submission of a completed application.

13. The City reserves the right to reject applications for assistance for buildings deemed beyond reasonable repair.
14. As a condition of the grant, the City may provide a building inspection team to determine the most urgent building needs. This inspection report will be considered part of the grant application. Previous Fire Department inspection reports will also be considered.

## **EVALUATION CRITERIA**

Applications for grant assistance are considered at the staff level, making sure it is complete and adheres to the published guidelines.

## **GRANT APPLICATION PROCESS**

1. Meet with the Grant Director to determine whether the grant is applicable to the project.
2. Turn in the completed application with all required attachments to the Grant Director, or such other person as the City Manager may designate. Please include 8 ½ x 11 copies of all drawings. Copies of attachments and drawings, which are needed to secure a building permit from the City, are also acceptable.
3. Review of the project and application to determine eligibility and the amount of grant assistance allowed within 21 business days of the submission of all required information. The Grant Director may request additional information if it considers the information supplied by the applicant to be insufficient. Upon the submission of all required information, the applicant may be contacted to schedule a tour of the project site and building. City inspection staff may be invited to come on the tour of the building.
4. Upon project completion (must be within 12 months of when the grant was approved), schedule a follow-up tour and submit actual project cost information, including copies of itemized invoices, receipts, and such other documentation as may be required by the grant agreement.
5. Upon receipt of evidence documenting actual project costs, the City shall have 30 days to confirm that such project costs were so incurred. Within 30 days after all the requirements set forth are met, the City shall issue a check for reimbursement of the costs incurred, up to the amount awarded.
6. City Commission will review the status of this grant program once a year to determine if any changes in the guidelines are necessary.

Approved by City Commission:

\_\_\_\_\_  
Date



**DOWNTOWN REVITALIZATION  
FAÇADE IMPROVEMENT GRANT APPLICATION**

Date of Application: \_\_\_\_/\_\_\_\_/\_\_\_\_

**Applicant Information**

Applicant Name: \_\_\_\_\_

Business Name: \_\_\_\_\_

Street Address: \_\_\_\_\_

City: \_\_\_\_\_ State: \_\_\_\_\_ Zip: \_\_\_\_\_

Phone Number: \_\_\_\_\_ Email address: \_\_\_\_\_

**Building Information**

Address of building where work is to be done: \_\_\_\_\_

Name of building owner (if different from above): \_\_\_\_\_

Building renter(s)/occupants: \_\_\_\_\_

**Financial Information**

Total amount of project: \$ \_\_\_\_\_

Total grant amount applied for: \$ \_\_\_\_\_

Guidelines:

Match must be 50/50 with City funds, using the following formula:

- Based on \$100 per building front foot
- Extra: for street corner buildings- add up to 25 feet if side has a display window
- Extra: for rear entrances facing a city parking lot- amount based on \$50 per building foot

Owner/Renter Matching Fund Source:

\_\_\_ Cash      \_\_\_ Bank financing      \_\_\_ Sweat Equity      \_\_\_ Other: \_\_\_\_\_

**Description of Improvements**

Describe the façade improvements (City matching funds can only be used for façade improvements):

\_\_\_\_\_

---

---

**DOWNTOWN REVITALIZATION  
FAÇADE IMPROVEMENT GRANT APPLICATION**

Describe how owner/renter funds to match City will be used :

---

---

---

Please attach the following:

- Copies of any written estimates for building improvements
- Drawings that show work to be done
- Pictures of building in present condition

Is a building permit required for the project? \_\_\_\_\_ Yes \_\_\_\_\_ No

If yes, describe:

---

---

**Project Timetable:**

Date work is to start:        \_\_\_/\_\_\_/\_\_\_

Date work is to be completed:    \_\_\_/\_\_\_/\_\_\_

Funds will be paid out once all work has been completed. Invoices or receipts must be furnished for all materials and labor.

**New or Expanding Business Information**

Will your building improvements create any new jobs?

---

If this is a new business, what goods or services are you going to provide?

---

---

**For More Information**

Contact the City of Liberal Grant Department at 620-626-2277. You may also fax your application to 620-626-0589 or email to: [kristyn.reust@cityofliberal.org](mailto:kristyn.reust@cityofliberal.org)

\_\_\_\_\_  
Applicant Signature

\_\_\_/\_\_\_/\_\_\_  
Date

\_\_\_\_\_  
Building Owner Signature

\_\_\_/\_\_\_/\_\_\_  
Date

Approved by: \_\_\_\_\_  
Grant Director

Approval Date: \_\_\_\_\_



**CITY OF LIBERAL  
CITY COMMISSION MEETING  
December 9, 2025  
AGENDA ITEM # 3.**

To: Mayor Jose Lara  
Vice Mayor Matt Landry  
Commissioner Ron Warren  
Commissioner Janeth Vazquez  
Commissioner Jeff Parsons

Date: December 9, 2025

From: Scarletta Diseker, City Manager

RE: Loraine Street Improvements Discussion

On July 8, 2025, the owners of parcels located on Loraine Avenue, which extends north from East 8th Street, requested that the Commission waive the subdivision regulations and allow them to install less than the required street improvements. The owners had already obtained a fill permit from KDHE-DWR at that time to place fill in the floodplain, making the parcels suitable for development.

Per our Building Services Director, Keith Bridenstine, the subdivision regulations require a minimum of a 35-foot-wide concrete or asphalt street to be installed prior to building structures on the parcels. The original improvement plans that were provided by the owners show the installation of a concrete street that meets the subdivision regulations. As the Zoning Administrator, he has no option to waive the required improvements, but the subdivision regulations do allow for the Commission to waive any improvement requirements if they are not technically feasible or necessary.

At the end of the July 8, 2025 meeting, the Commission voted to uphold the regulations as written but asked for City Staff to possibly pursue the RHID incentive option.

On July 17, 2025, City Staff held a meeting with the landowners to discuss their improvements and run cash flow analysis numbers. Our Finance Director, Kristyn Reust, and Grants Director, Karen LaFreniere, will review the Commission on those numbers and take questions about whether we want to move forward with a possible RHID or reconsider a waiver.

**Recommendation:**



1013

822

816

810

1011

LORRAINE AVE

1015

E 8TH ST

912

916

918

920

924

Rosa Quinonez  
1100 Balboa St  
Liberal, Ks 67901  
rosamayte11@icloud.com  
620-417-4853

**Date:** 06/19/2025

**To:**  
Body of City Commission of Liberal

Dear Members,

I hope this letter finds you well. I am writing to formally appeal to the requirement for street improvements on my property located at 816 Loraine Ave, as I received regarding the planned development of my property. I understand the need for infrastructure development, but I would like to request reconsideration of this requirement due to the significant financial hardship it would impose on me, as well as the unnecessary use of public access that such improvements would involve.

#### **Financial Hardship**

As a property owner, I am currently facing considerable financial strain, which makes it difficult, if not impossible, to fund the street improvement required for development. The added cost of these improvements would prevent me from moving forward with the development project, which would not only delay my ability to utilize my property but also impose an undue burden on my personal finances. I am asking for your understanding and consideration of the financial impact that this requirement has on me as a property owner.

#### **Unnecessary Use of Public Access**

Additionally, I believe that the requirement for street improvements would unnecessarily affect public access. The proposed development is situated in an area where the existing infrastructure and road conditions already meet the needs of the surrounding area and do not significantly impact public safety or access. Given that the property is not expected to significantly increase traffic or cause a strain on the existing road system, I feel that the imposition of these street improvements would be excessive to the broader goals of development in the area at this time.

In light of these factors, I kindly request that you reconsider the requirement for street improvements on my property, taking into account the financial hardship I am facing and the limited necessity of the improvements in terms of public access and safety.

Thank you for your time and attention to this matter.

Sincerely,  
**Rosa Quinonez**

## ARTICLE 7. INSTALLATION OF REQUIRED IMPROVEMENTS

100. **Engineering Responsibility.** In setting certain standards and specifications, approving engineering drawings, inspecting improvements, recommending acceptance of improvements, preparing petition forms and establishing the amount of surety for guaranteeing the installation of such improvements; the engineer designated by the City or utility company representative shall be designated as responsible for the improvements within their respective jurisdictions. Coordination to achieve cooperation among the responsible parties is the responsibility of the City and, in particular, the Subdivision Administrator.
101. **Required Improvements.** As a condition to final plat approval, the subdivider of a proposed subdivision shall be responsible to install or, in cooperation with the Governing Body and utility companies, cause to be installed the following necessary facilities and improvements as listed below. The design and installation of such facilities and improvements shall include such sizing of pipes and extensions of streets as may be deemed desirable within the subdivision to facilitate development of adjacent land.
- A. All streets, alleys, curbs, gutters and street drainage facilities shall be constructed in accordance with established City standards. **Streets shall be constructed of concrete, asphalt or asphaltic concrete and no gravel or sanded roadways shall be constructed.** To accommodate any future improvements, the entire right-of-way of collector and local streets shall be graded to match the level of the road surface. All stumps, trees that cannot be saved, boulders and similar items shall be removed from such right-of-way.
- B. A storm drainage system shall be provided, separate and independent of the sanitary sewer system, meeting all of the specifications and requirements of the City. Such storm drainage system shall be connected to any existing storm sewer system, where available, or if such connection is not available, other adequate means for the discharge of such storm water including the use of detention ponds shall be provided by the subdivider into the nearest major water channel. If it is determined that adequate drainage can be accomplished by a natural drainage way across private property, a drainage easement may be required; however, any initial channelization is the responsibility of the subdivider and continued maintenance the responsibility of the adjacent property owner(s).
- C. Sidewalks shall be constructed in accordance with standards set by the City under the following conditions:

ARTICLE 11. APPEALS, WAIVERS AND MODIFICATIONS

100. **Appeals General.** The subdivider of a proposed subdivision may appeal decisions made in the enforcement of these regulations by the Subdivision Administrator to the Planning Commission and by the Planning Commission to the Governing Body. In the even the Governing Body sustains the Planning Commission, the action of the Planning Commission shall be final except as otherwise provided by law. If the Governing Body overrules the Planning Commission, the Governing Body shall make its decision, in writing or in the minutes of the meeting, stating the reason therefore and return such decision and plat to the Planning Commission for consideration of reapproval.
101. **Appeals on Improvement Standards.** Any appeal as to approval of standards or plans and engineering drawings in connection with required improvements shall be directed to the Governing Body and that action shall be final.
102. **Waiver of Required Improvements.** Any waiver of the required improvements may be made only by the Governing Body on a showing that such improvements are not technically feasible or necessary.
103. **Modifications.** In cases in which there is unwarranted hardship in carrying out the literal provisions of these regulations as to design criteria, the Planning Commission may grant a modification from such provision according to the following guidelines:
- A. A request for a modification shall be made to the Subdivision Administrator who shall transmit it to the Planning Commission. The Planning Commission shall give the subdivider and any other interested person an opportunity to be heard with respect to the requested modification.
  - B. The Planning Commission shall not grant a modification unless it shall find that (1) the strict application of theses regulations will create an unwarranted hardship; (2) modification is in harmony with the general spirit and intended purpose of these regulations; (3) the rights of adjacent property owners will not adversely be affected: and (4) the public safety, health and general welfare will be protected.
  - C. When used in this Section, the term “unwarranted hardship” shall mean the effective deprivation of use as distinguished from a mere inconvenience.
  - D. Modifications permitted under the provisions of this Article shall not include modifications from the requirements of improvement

# BEATYS EASTLAND ADDITION BLOCK 3 LOTS 10-12

## LIBERAL, KANSAS

Project Number: 23-32

### INDEX TO SHEETS

SHEET NO.	DESCRIPTION
1	Title Sheet
2	Site Plan
3	Grading Plan LOMR-F
4	Typical Section & Valley Gutter
5	Cross Sections

### GENERAL NOTES

- 1) Utilities shall be located prior to beginning construction utilities as shown on plans are approximate in location. The location, depth and size of utilities are not guaranteed for complete accuracy. Damaged utilities from construction activities shall be repaired by the contractor at their expense.

Kansas One-Call 800-344-7233

#### Utility Owners - Liberal, Ks

ATT Distribution	(800) 778-9140
Zito Media	(620) 624-1634
C/Liberal-Wtr & Sew	(620) 626-0138
Black Hills Energy	(888) 890-5554
Southern Pioneer Elect	(800) 670-4381

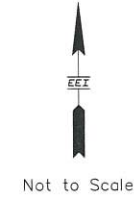

- 2) The contractor shall be responsible for maintaining property corners and control points. If damaged during construction, points shall be reset by a licensed surveyor with the State of Kansas at contractor expense.
- 3) Sewer and water construction shall be coordinated with the city utility department. Installation shall be in accordance with city utility specifications. The City uses Mueller Centorian (3-Way) Fire Hydrants and Mueller Water Valves within their system. No Substitutes will be accepted or approved for use.
- 3a) Sewer and water construction shall meet City of Liberal, KS, & KDHE Specifications.
- 4) Work to be completed within the city right of way shall meet all city specifications and standards for such work. This work must be coordinated and inspected by city staff.
- 5) The site shall be kept neat and orderly. Trash and waste shall be contained and disposed of on a regular basis.
- 6) Concrete pavement and curb & gutter shall meet required 28-day strength of 4000 psi. Air entrainment shall be within the range of 5% to 7%. Aggregates for pavement shall be in conformance with the current KDOT specification for on grade concrete aggregates. Maximum Concrete slump shall be 4". Concrete construction within city right of way shall be in conformance with city specifications. The use of water reducers and accelerators within the city right of way shall be approved by the city prior to use. Concrete pavements shall be protected from freezing in accordance with ACI 306.
- 7) Wire mesh where called out in the plans shall be centered in the slab on supports. Adequate supports shall be provided to maintain the position of the mesh during construction. 2" clearance between the mesh and tie bars and dowels shall be provided.
- 8) Contractor is responsible for providing equipment capable of compacting subgrades to the specified densities. Moisture content within the soil shall be sufficient to achieve required density or as specified within the geotechnical report (if provided). Loose soil lifts should not exceed 8 inches. Stripped top soil may be stock piled and used for final grading. The contractor shall take necessary precautions to prevent stock piles from eroding or becoming air-borne.
- 9) Crack Control Fiber Reinforcement shall be used in curb & gutter construction. Dosage amount shall be per manufacture recommendations.
- 10) Imported fill required for constructing pavements shall be granular with a PI < 20. Expansive soils (AASHTO A5-A7) should be avoided for construction. Unless otherwise specified, compaction should be 95% of the soil proctor. Soil proctors shall be completed conforming to ASTM D698.
- 11) Airborne dust from construction activities shall be minimized. The contractor shall water the site on a regular basis and as required to keep loose soil from becoming airborne.
- 12) Mud tracking on city streets is prohibited. The contractor shall maintain a clean entrance and clean equipment as necessary to keep mud accumulation off city streets.
- 13) Fence Removed as required for construction shall be coordinated with the property owner and re-installed to it's existing condition.
- 14) Tree removal or trimming shall be avoided if possible. If not possible the work shall be coordinated and approved by individual property owner.
- 15) Excavation from project may be hauled to the Southwest drainage pond located approximately 1/4 mile South of US 54 and Western Ave.

### LEGEND

— P —	Property Line
— E —	Easement
— S —	Section Line
— UGT —	Existing Underground Telephone
□ T	Existing Telephone Riser
— UTV —	Existing Underground Cable Television
— UGE —	Existing Underground Electrical
□ P	Existing Power Pole
□ LP	Existing Light Pole
— G-3s —	Existing Gas Line
□ GM	Existing Gas Meter
— 6" W —	Existing 6" Water Line
□ X	Existing Water Valve
□ F	Existing Fire Hydrant
□ M	Existing Water Meter
— 8" SS —	Existing 8" Sanitary Sewer Line
□ O	Existing Sanitary Sewer Manhole
□ CO	Existing Sanitary Sewer Clean-Out
— 6" W —	New 6" Water Line
□ X	New Water Valve
□ F	New Fire Hydrant
— 8" SS —	New 8" Sanitary Sewer
□ O	New Sanitary Sewer Manhole
□ CO	New Sanitary Sewer Clean-Out
□ X	Remove Tree
— X —	Existing Fence
□ X	Removal
□ X	Sp. Trench Compaction (3' Typ. Width)
□ X	5' Curb Transition
□ X	Entrance Curb

May 2025

PLANS PREPARED BY

**EARLES ENGINEERING & INSPECTION, INC.**

Civil & Structural Engineers—Construction Inspectors—Surveyors

Revised By: LARISA CASTANON  
 Plotted: 5/1/2025 10:56 AM

Filename: 23-32\_SITE\_PLANDWG  
 File Location: G:\LEUB\2023\23-32\CAD\DWG\Plan\_Set

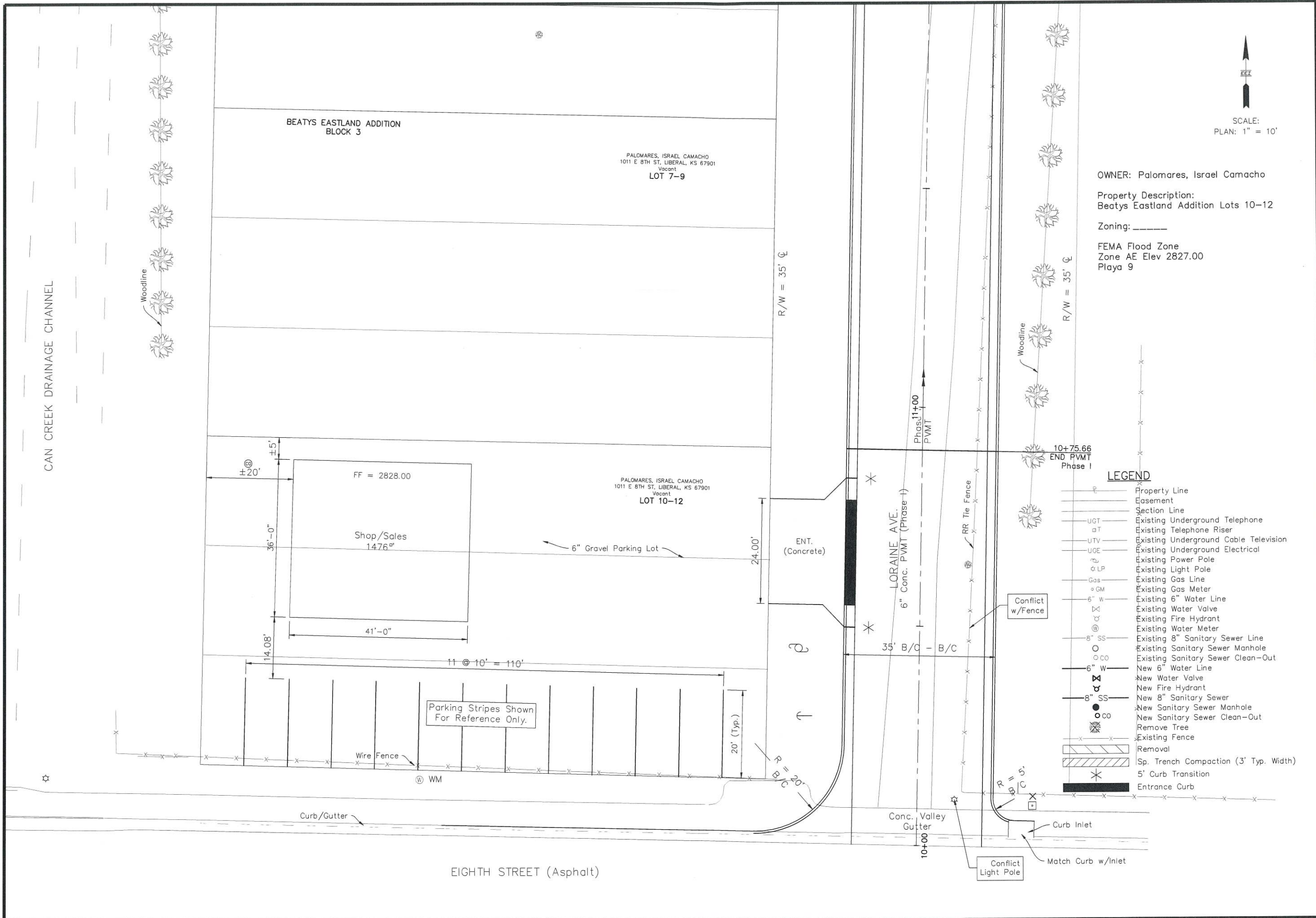

OWNER: Palomares, Israel Camacho  
 Property Description:  
 Beatys Eastland Addition Lots 10-12  
 Zoning: \_\_\_\_\_  
 FEMA Flood Zone  
 Zone AE Elev 2827.00  
 Playa 9

**LEGEND**

- P — Property Line
- E — Easement
- S — Section Line
- UGT — Existing Underground Telephone
- UT — Existing Telephone Riser
- UTV — Existing Underground Cable Television
- UGE — Existing Underground Electrical
- P — Existing Power Pole
- LP — Existing Light Pole
- Gas — Existing Gas Line
- GM — Existing Gas Meter
- 6" W — Existing 6" Water Line
- W — Existing Water Valve
- FH — Existing Fire Hydrant
- WM — Existing Water Meter
- 8" SS — Existing 8" Sanitary Sewer Line
- SS — Existing Sanitary Sewer Manhole
- SS-CO — Existing Sanitary Sewer Clean-Out
- 6" W — New 6" Water Line
- W — New Water Valve
- FH — New Fire Hydrant
- SS — New 8" Sanitary Sewer
- SS-CO — New Sanitary Sewer Manhole
- SS-CO — New Sanitary Sewer Clean-Out
- T — Remove Tree
- F — Existing Fence
- R — Removal
- Sp. Trench Compaction (3' Typ. Width)
- C — 5' Curb Transition
- C — Entrance Curb

NO.	DATE	DESCRIPTION

**EARLES ENGINEERING & INSPECTION, INC.**  
 Civil & Structural Engineers  
 Construction Inspectors—Surveyors  
 Email: earlesinc@earleseng.com

**BEATYS EASTLAND ADDITION BLOCK 3 LOTS 10-12**  
**SITE PLAN**  
 KANSAS  
 CITY OF LIBERAL

**PRELIMINARY DRAWING**

ENGINEER: TJS  
 CHECKED BY: TJS  
 DRAWN BY: LC  
 DATE: 5/8/2025  
 PROJECT NO: 23-32  
 SHEET: 2 of 5

Revised By: LARISA CASTANON  
 Plotted: 5/8/2025 11:11 AM

Filename: 23-32\_GRAVING PLAN.DWG  
 File Location: G:\ELIB\2023\23-32\CAD\DWG\Plan\_Set

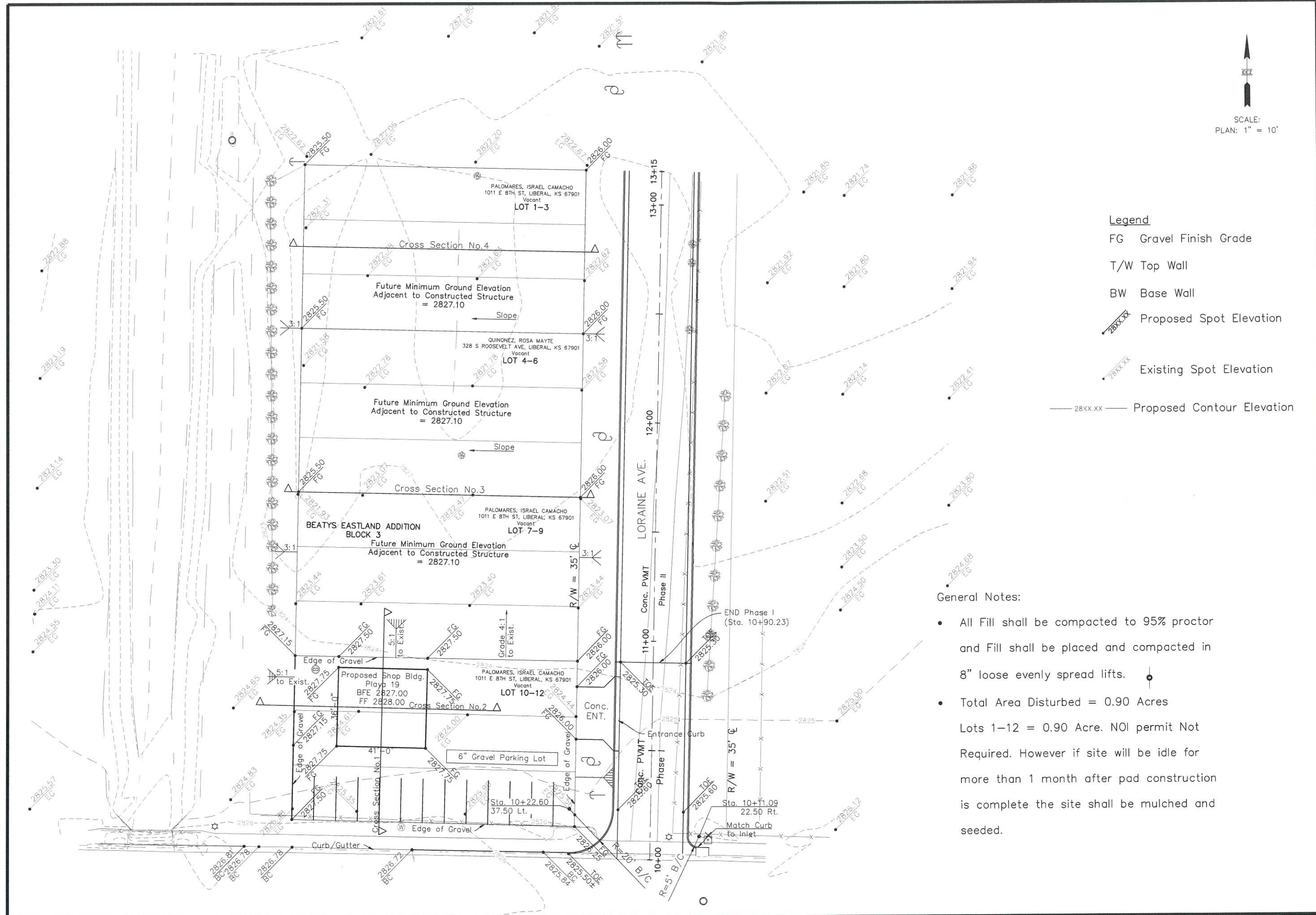

SCALE:  
 PLAN: 1" = 10'

- Legend**
- FG Gravel Finish Grade
  - T/W Top Wall
  - BW Base Wall
  - Proposed Spot Elevation
  - Existing Spot Elevation
  - Proposed Contour Elevation

**General Notes:**

- All Fill shall be compacted to 95% proctor and Fill shall be placed and compacted in 8" loose evenly spread lifts.
- Total Area Disturbed = 0.90 Acres  
 Lots 1-12 = 0.90 Acre. NOI permit Not Required. However if site will be idle for more than 1 month after pad construction is complete the site shall be mulched and seeded.

NO.	DATE	REVISIONS DESCRIPTION

**EARLES ENGINEERING & INSPECTION, INC.**  
 Civil & Structural Engineers  
 Construction Inspectors—Surveyors  
 Email: earlesinc@earleseng.com

**BEATYS EASTLAND ADDITION BLOCK 3 LOTS 10-12**  
**GRAVING PLAN LOMR-F**  
 KANSAS  
 CITY OF LIBERAL



ENGINEER:	TJS
CHECKED BY:	TJS
DRAWN BY:	LC
DATE:	5/8/2025
PROJECT NO:	23-32
SHEET:	3 of 5

Reviewed By: LARISA CASTANON  
 Plotted: 10/6/2023 9:03 AM  
 Filename: 23-32\_TYPICAL SECTION & VALLEY GUTTER.DWG  
 File Location: G:\LELBA\2023\23-32\CAD\DWG\Plan\_Set

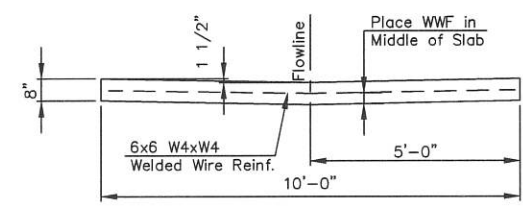
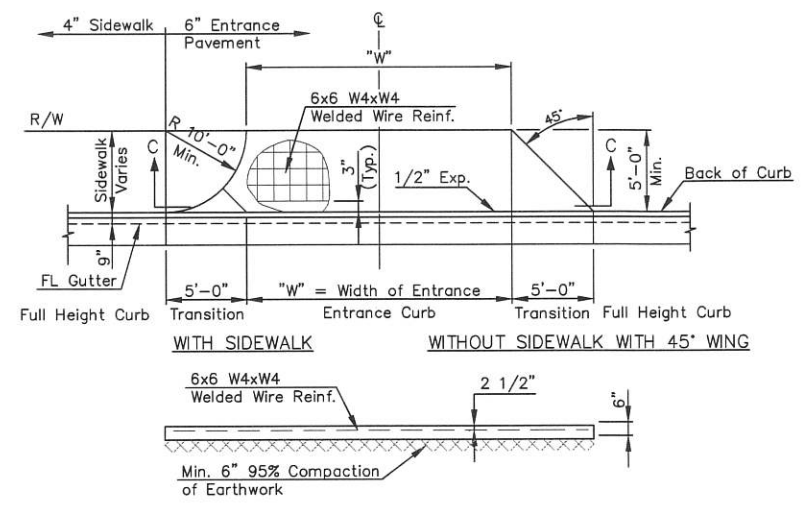
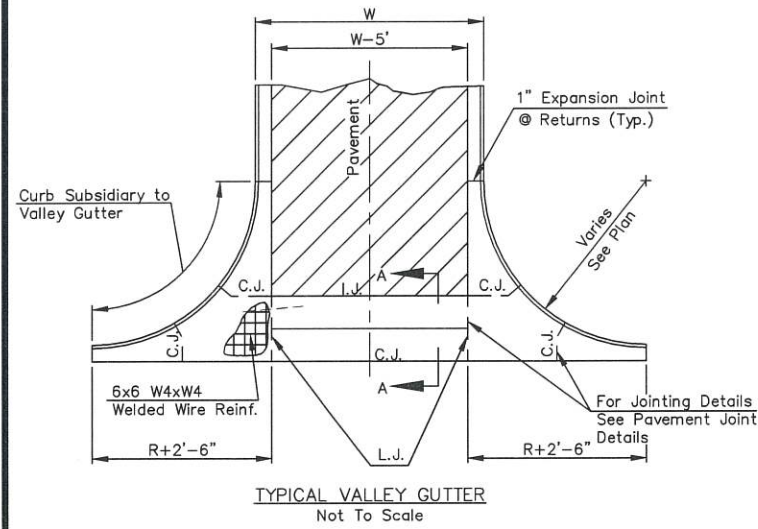

SECTION C-C  
TYPICAL ENTRANCE PAVEMENT  
TYPICAL PLAN FOR  
NORMAL ENTRANCE PAVEMENT  
Not to Scale

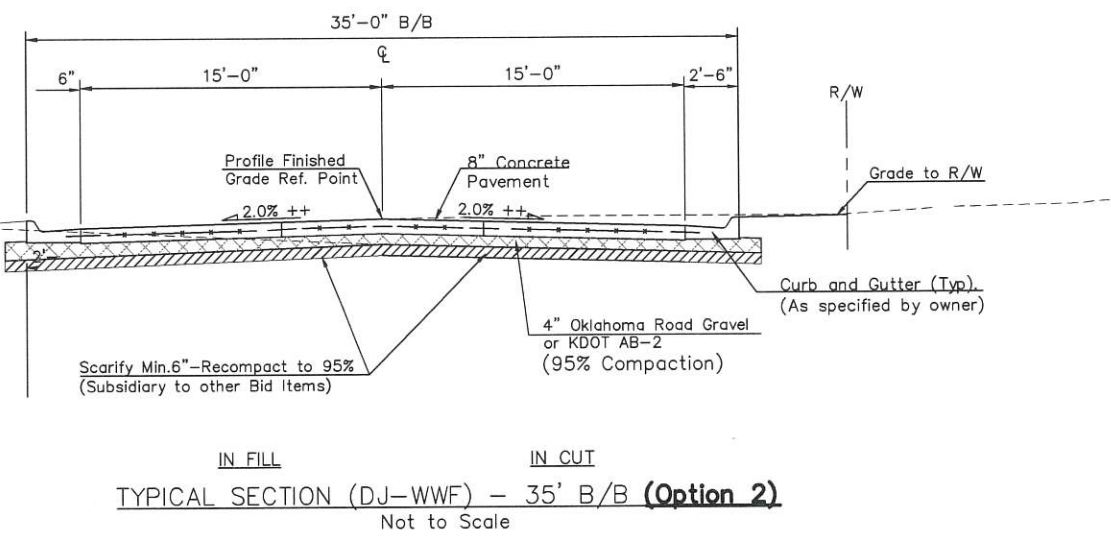
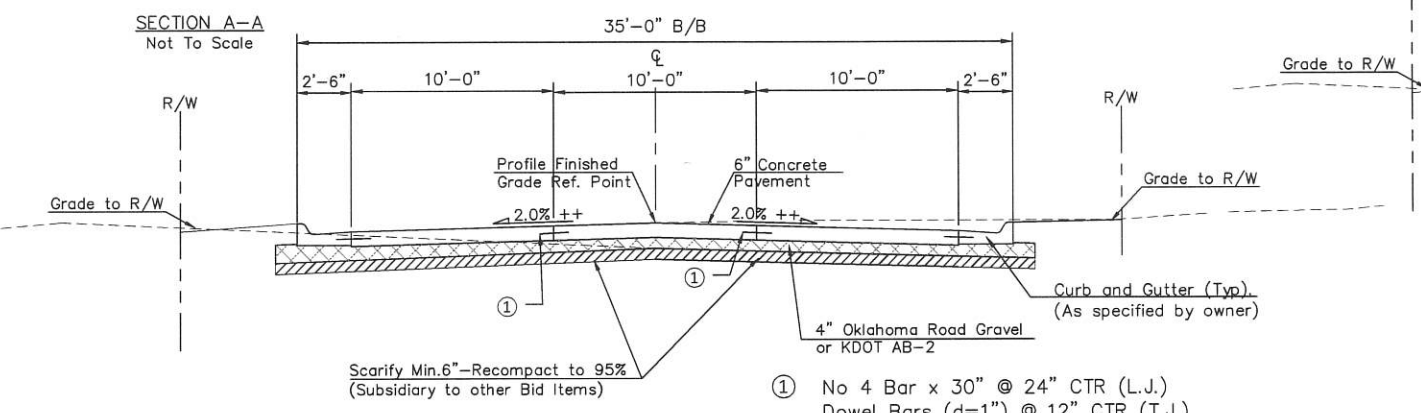

IN FILL IN CUT  
TYPICAL SECTION (NRDJ) - 35' B/B (Option 1)  
Not to Scale

IN FILL IN CUT  
TYPICAL SECTION (DJ-WWF) - 35' B/B (Option 2)  
Not to Scale

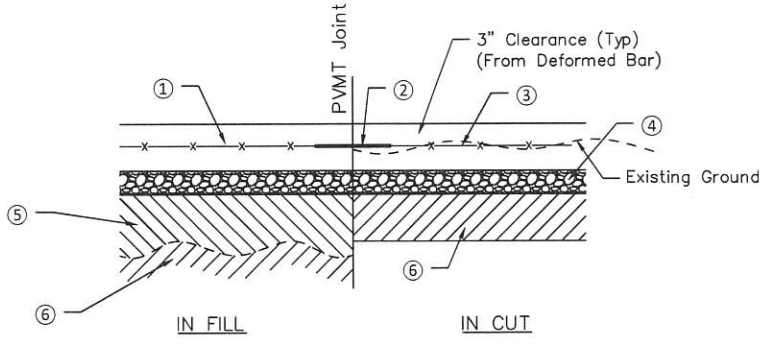
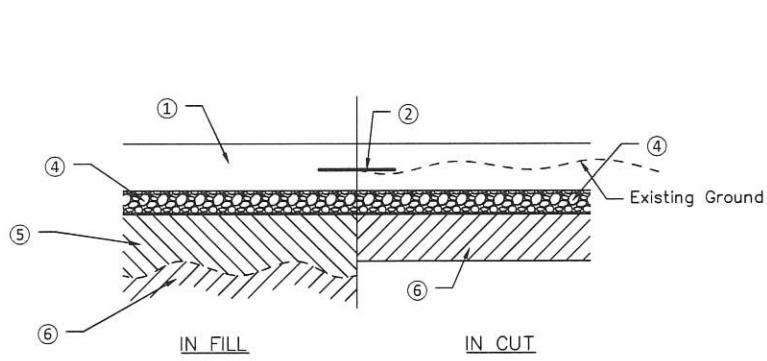

- ① Pavement - See TYP Section
- ② Deformed Bar (No 4 x 30") @ 24" Ctr
- ④ Base (KDOT AB-2 or Oklahoma Road Gravel)(4")
- ⑤ Fill as required (PI < 20) Compact 95% Proctor
- ⑥ Subgrade (6") Scarify/Compact 95% Proctor (Subsidiary to other Bid Items)

- ① Pavement - See TYP Section
- ② Deformed Bar (No 4 x 30") @ 24" Ctr
- ③ WWF(6 gauge x 0.080 sq.in.)
- ④ Base (KDOT AB-2 or Oklahoma Road Gravel)(4")
- ⑤ Fill as required (PI < 20) Compact 95% Proctor
- ⑥ Subgrade (6") Scarify/Compact 95% Proctor (Subsidiary to other Bid Items)

PAVEMENT SECTION (NRDJ)(Option 1)

PAVEMENT SECTION (DJ-WWF)(Option 2)

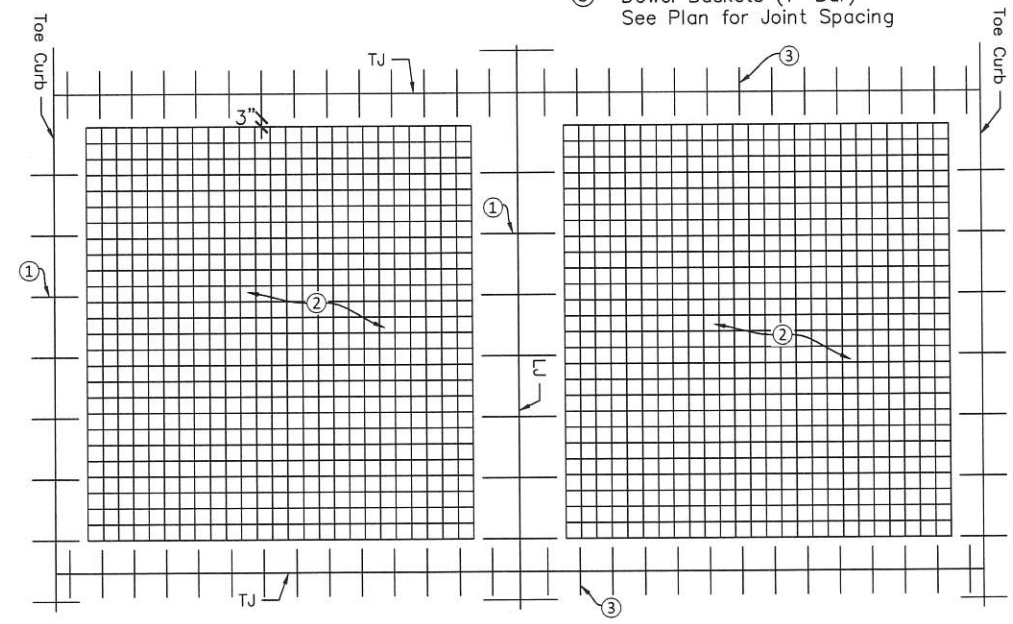

PLAN (DJ-WWF)(Option 2)

GENERAL NOTES

1. Pre-molded expansion joint filler (Type B) (non-extruding) will be used at all expansion joints.
2. One Inch Expansion Joints shall be placed at all curb returns.
3. One inch expansion joints shall be placed in curb at 300± feet for bituminous pavement, or to match expansion joints in concrete pavement.
4. Relief cuts shall be placed in curb every 6 feet for bituminous pavement: 6 feet max and at curb transverse joints in concrete pavement.
5. Isolation joints shall use thickened pavement, which will not be paid for separately and shall be considered SUBSIDIARY to pavement.
6. Pavement, sidewalk, and entrances shall be removed to the nearest existing joint or saw cut to neat lines, as directed by engineer. Saw cutting to neat lines shall be subsidiary to the respective removal quantities.
7. Adjusting manhole will include replacing the existing ring and cover with new solid Manhole lid. The ring and cover will be Deeter 1005-A or equal.
8. Unless otherwise specified or approved ALL concrete shall be 4000 psi at 28 day w/ 5 ±1% air entrainment for pavements and curb/gutter.
9. Subgrade and base compaction shall be Subsidiary to other Bid Items. Compaction of required fill will be paid as a bid item.

NO.	DATE	REVISIONS DESCRIPTION

**EARLES ENGINEERING & INSPECTION, INC.**  
 Civil & Structural Engineers  
 Construction Inspectors-Surveyors  
 Email: earlesinc@earleseng.com

**BEATYS EASTLAND ADDITION BLOCK 3 LOTS 10-12**  
**TYPICAL SECTION & VALLEY GUTTER**  
 KANSAS  
 CITY OF LIBERAL

**PRELIMINARY DRAWING**

ENGINEER:	TJS
CHECKED BY:	TJS
DRAWN BY:	LC
DATE:	5/8/2025
PROJECT NO:	23-32
SHEET:	4 of 5

Revised By: LARISA CASTANON  
 Plotter: 5/8/2025 11:12 AM

Filename: 23-32\_CROSS SECTIONS.DWG  
 File Location: G:\LEEB\2023\23-32\CAD\DWG\Plan\_Set

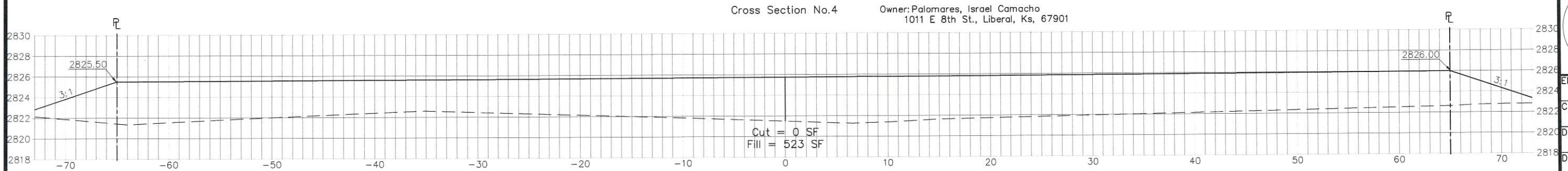
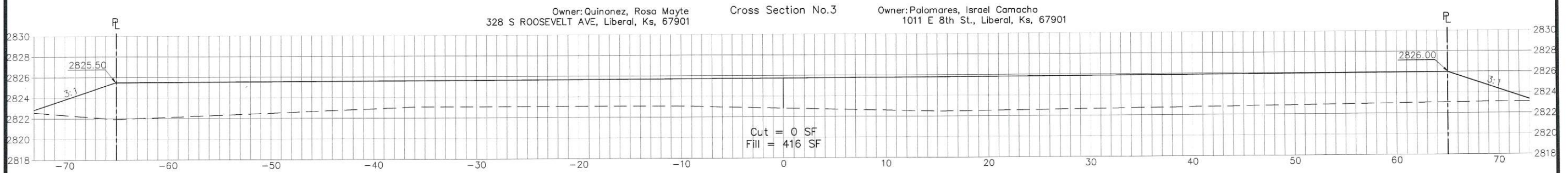
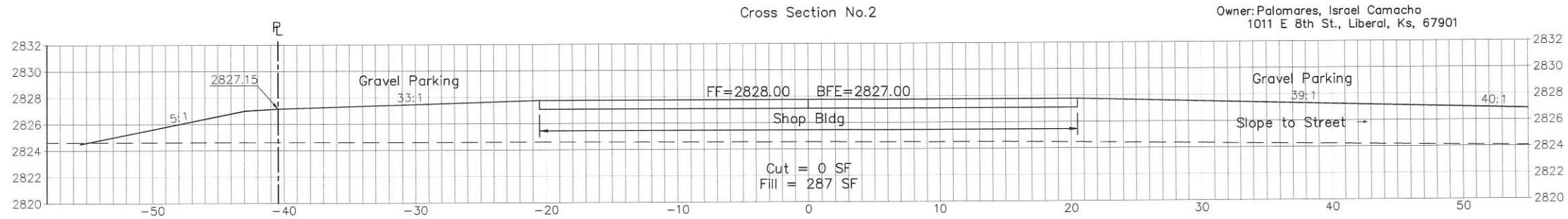
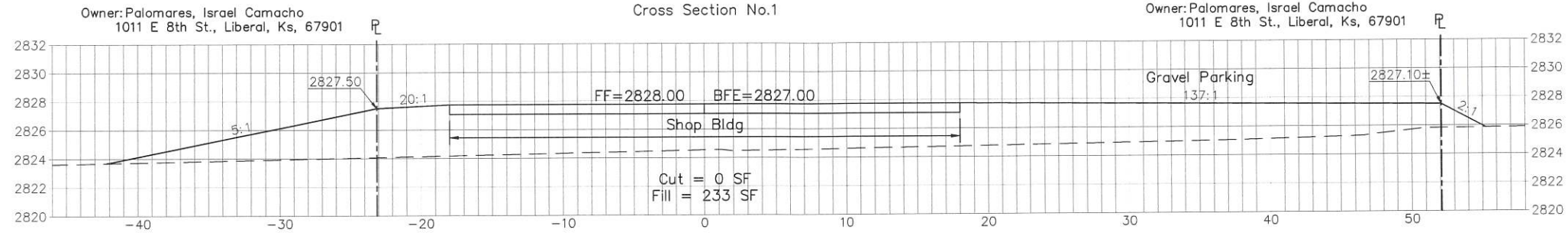

NO.	DATE	REVISIONS DESCRIPTION

**EARLES ENGINEERING & INSPECTION, INC.**  
 Civil & Structural Engineers  
 Construction Inspectors-Surveyors  
 Email: earlesinc@earleseng.com

**BEATYS EASTLAND ADDITION BLOCK 3 LOTS 10-12**  
**CROSS SECTIONS**  
 KANSAS  
 CITY OF LIBERAL

**PRELIMINARY DRAWING**

ENGINEER: TJS  
 CHECKED BY: TJS  
 DRAWN BY: LC  
 DATE: 5/8/2025  
 PROJECT NO: 23-32  
 SHEET: 5 of 5

Mike Beam, Secretary

Laura Kelly, Governor

June 16, 2025

ISRAEL CAMCHO PALOMARES  
P.O. BOX 336  
TYRONE, OK 73951

Re: Beatys Eastland Addition Block 3 Lots 1-12  
Permit Amendment  
WSN: LSW-0018, Notice No.: 2023307

Dear Mr. Israel Camcho Palomares:

Enclosed is the Permit Amendment by the Chief Engineer, Division of Water Resources, Kansas Department of Agriculture, which appends to the permit dated January 31, 2024, to show additional consent under the file number referred to above.

The permit and approval of plans are modified to show:

Consent to the placement of fill to construct a residential slab on grade structure on Lots 1-9 and a building and parking lot on Lots 10-12 in the floodplain of local drainage at a location in the SW ¼ of the NE ¼ of Section 33, Township 34 South, Range 33 West, Seward County, Kansas.

An additional condition has been added to the permit to require a Letter of Map Revision (LOMR) shall be obtained from the Federal Emergency Management Agency to document any changes to the floodplain or floodway boundaries.

Should you have any questions, please feel free to contact this office. If you wish to refer to a specific file, please reference it when you contact us.

Sincerely,

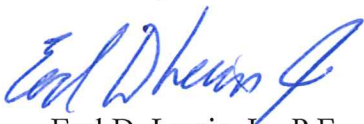

Earl D. Lewis, Jr., P.E.  
Chief Engineer  
Division of Water Resources  
Kansas Department of Agriculture

Enclosure

pc: Trever Stoppel – Earles Engineering & Inspection, Inc.

THE STATE  OF KANSAS

KANSAS DEPARTMENT OF AGRICULTURE  
Mike Beam, Secretary of Agriculture

DIVISION OF WATER RESOURCES  
Earl D. Lewis Jr., Chief Engineer

PERMIT AMENDMENT  
IN THE MATTER OF THE  
Permit No. LSW- 0018

It has been determined that in the Permit by the Chief Engineer, Division of Water Resources, Kansas Department of Agriculture, dated January 31, 2024, issued pursuant to K.S.A. 24-126, described as giving his consent to:

the placement of fill for construction of an elevated pad in the floodplain of local drainage at a location in the SW 1/4 of the NE 1/4 of Section 33, Township 34 South, Range 33 West, Seward County, Kansas.

Now, Therefore, it is the decision and order of the Chief Engineer, Division of Water Resources, Kansas Department of Agriculture, that additional activity is proposed in the Permit dated January 31, 2024, issued pursuant to Israel Camacho Palomares. The same should be and is hereby amended now, as of then, to show consent to:

the placement of fill to construct a residential slab on grade structure on Lots 1-9 and a building and parking lot on Lots 10-12 in the floodplain of local drainage at a location in the SW 1/4 of the NE 1/4 of Section 33, Township 34 South, Range 33 West, Seward County, Kansas.

In all other respects, the permit is as approved on June , 2025.

Witness my hand this 16<sup>th</sup> day of June, 2025.

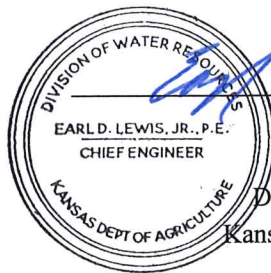

*Earl D. Lewis Jr.*

Earl D. Lewis Jr., P.E.  
Chief Engineer  
Division of Water Resources  
Kansas Department of Agriculture

State of Kansas )  
)SS  
County of Riley )

The foregoing instrument was acknowledged before me this 16<sup>th</sup> day of June, 2025, by Earl D. Lewis, Jr. Chief Engineer, Division of Water Resources, Kansas Department of Agriculture.

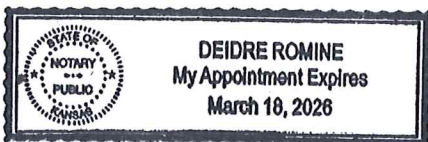

*Deidre Romine*  
Notary Public



**CITY OF LIBERAL  
CITY COMMISSION MEETING  
December 9, 2025  
AGENDA ITEM # 4.**

To: Mayor Jose Lara  
Vice Mayor Matt Landry  
Commissioner Ron Warren  
Commissioner Janeth Vazquez  
Commissioner Jeff Parsons

Date: December 9, 2025

From: Scarlette Diseker, City Manager

RE: Engineering Discussion

City Staff would like to have open discussion regarding whether we would like to solicit and move forward with a Master Agreement for City engineering services or if we would like to continue with on-demand requests as they arise.

At the present time, we reach out to local firms when project planning and services are needed. A Master Engineering Agreement with a specific firm would allow more consistent communication and monthly, in-person meetings to discuss needs, review projects, and plan for Commission presentations.

**Recommendation:**



**CITY OF LIBERAL  
CITY COMMISSION MEETING  
December 9, 2025  
AGENDA ITEM # 5.**

To: Mayor Jose Lara  
Vice Mayor Matt Landry  
Commissioner Ron Warren  
Commissioner Janeth Vazquez  
Commissioner Jeff Parsons

Date: December 9, 2025

From: Scarletta Diseker, City Manager

RE: Airport Hangar Assessment Discussion

The Skyhawk Hangar, located onsite at the Mid-America Air Museum, is a surviving historical artifact from the early 40's when Liberal was selected as a B-24 training base during WWII. After much discussion with the MAAM Foundation, we have confirmed that there is a desire to explore the possibility of rehabilitating it into a useful space, whether it be an extension of the museum for displays and traveling exhibits or potentially something more grand like a convention center or meeting space.

City Staff will have John T. Smith from the MAAM Foundation give comments on how we can take a step forward to request and fund a preliminary assessment through a RFQ, RFI, or RFP process.

Throughout our conversations this year, the City's main focus and questions have centered around:

- 1) Cost of Assessment
- 2) Foundation Contribution
- 3) Proposed Use of Hangar
- 4) Interested Firms with Expertise
- 5) Grant Funding Options

Kristyn Reust, our current Finance Director, will give several grant funding options to consider, as a project of this magnitude would require City Staff to research and apply for multiple funding opportunities.

We last visited this subject during the Non-Profit Hearings, where the City Commission felt that an assessment would be necessary due to the building belonging to us, but they chose not to fund it through the non-profit appropriation process. Instead, a request was made to revisit it at a later date following the completion of the 2026 Budget.

We currently have a cash balance of \$36,758.31 sitting in the 301 Construction Fund under the "Air Museum Rebrand" project. These funds appear to have originated from Tourism and have sat idle for several years without being transferred back. We feel these dollars could assist in a match with the Foundation to obtain an assessment of the hanger.

**Recommendation:**

## **Options for Funding and Preserving the Skyhawk Building**

There are viable alternative funding and preservation strategies beyond direct city budget allocations. These focus on storm damage repair (\$175k for roof and windows), broader stabilization, and adaptive reuse as an aviation exhibit space. Prioritizing historic designation is key, as many programs require it. First, we would need to apply to the Kansas State Historic Preservation Office (SHPO) for listing on the Kansas Register of Historic Places (quick process, 3-6 months) or National Register of Historic Places (federal recognition, unlocks more funds).

I've prioritized options relevant to Kansas municipalities, aviation history, and recent disaster recovery. Our match requirements (usually 20%) can often be met with in-kind contributions like volunteer labor or city services. We can consult with SHPO ([kshs.org](http://kshs.org)).

### **1. Pursue Historic Designation to Unlock Grants**

- Why? Listing qualifies the building for preservation incentives without upfront costs. It's not yet listed, but WWII aviation structures like this often qualify.
- Process: Submit nomination to Kansas SHPO (no fee for owners). Use as leverage for immediate stabilization.
- Timeline: 3-12 months.
- Next Step: Contact SHPO at 785-272-8681 for a free eligibility review.

### **2. State-Level Preservation Grants**

These are administered through Kansas SHPO or Department of Commerce and can cover emergency repairs.

Grant Program	Description & Eligibility	Funding Amount	Match Required?	Application Notes
Heritage Trust Fund (HTF) <a href="http://ncrpc.org">ncrpc.org</a>	Grants for physical preservation/restoration of historic properties (roof/window repairs, aviation exhibits). Eligible post-listing; municipalities qualify	\$5,000–\$100,000	Yes (20% minimum)	Annual deadline March; next cycle opens early 2026. Covers non-downtown sites like airports.
Historic Economic Asset Lifeline (HEAL) <a href="http://kansasco.commerce.gov">kansasco.commerce.gov</a>	Matching funds for rehab of underutilized/vacant historic buildings to spur economic activity (museum expansion). Open to cities <50,000 pop, aviation tourism fits.	Up to \$150,000 (matching)	Yes (1:1)	Rolling applications; quick disbursement for urgent needs. Airport location may qualify if tied to tourism/economic impact.
Culture Preservation Grants (Humanities Kansas) <a href="http://humanitieskansas.org">humanitieskansas.org</a>	Supports access to cultural resources (digitizing WWII aviation archives while repairing structure). Nonprofits/municipalities eligible; no listing required.	Up to \$3,500	No	Deadlines: Feb 28, June 30, Oct 31, 2026. Quick turnaround for small emergency fixes.

### 3. Federal and Disaster Recovery Options

Least likely.

Program	Description & Eligibility	Funding Amount	Match Required?	Application Notes
Historic Preservation Fund (HPF) – Disaster Recovery Grants <a href="https://nps.gov/aba">nps.gov/aba</a> <a href="https://ndonedatlas.com">ndonedatlas.com</a>	Federal pass-through via SHPO for emergency repairs to historic sites post-disaster. Aviation/WWII sites prioritized; no listing needed for initial stabilization.	Varies (\$50k+ possible)	Often waived for disasters	Apply via SHPO, funds from NPS for recent events like storms. If declared, could cover full \$175k repair.
SBA Disaster Loans for Nonprofits/Municipalities	Low-interest loans for physical damage/economic injury from storms. Museums/public facilities eligible if tied to community services.	Up to \$2M (loans)	No (but repayment)	Apply online at <a href="https://sba.gov/disaster">sba.gov/disaster</a> ; open for June 2025 KS storms—request extension for Nov event.
Airport Improvement Program (AIP) Grants	FAA funds via Kansas Dept. of Transportation (KDOT) for airport infrastructure preservation (historic hangars). Safety/liability fixes qualify.	\$100k–millions	Varies (10-30%)	Annual KDOT cycle; emphasize aviation heritage/tourism. Contact KDOT Aviation at 785-296-3245.

#### 4. Aviation-Specific and Private Funding

Tap into organizations focused on aviation history for targeted support.

- Experimental Aircraft Association (EAA) Chapter Grants: Local EAA chapters (e.g., in Wichita or Garden City) offer small grants/loans for WWII aircraft facilities. Up to \$10k, no match. Apply via [eaa.org](http://eaa.org), pitch as MAAM expansion.
- Aircraft Owners and Pilots Association (AOPA) Foundation: Grants for airport historic preservation. \$5k–\$25k, aviation museums eligible. Deadline: Rolling, [aopa.org](http://aopa.org).
- DAR Historic Preservation Grants: Up to \$10k for WWII-era sites (repairs + markers). Municipalities/nonprofits qualify, all eras eligible. Annual deadline-Feb 2026.
- National Trust for Historic Preservation Grants: Planning grants for surveys/assessments (\$5k–\$15k) to build rehab case. No listing required initially.

#### 5. Community and Alternative Strategies

- Partnerships: Kansas-specific platform (e.g., via KS Wildlife Federation) tied to MAAM's board vision. Partner with local aviation clubs or veterans' groups for matching donations. Aim for \$20k–\$50k in 30-60 days.
- Economic Development Incentives: Apply for Community Development Block Grants (CDBG) via Kansas Dept. of Commerce for tourism-boosting rehab (up to \$500k; 51% low/moderate-income benefit required- Would need to do door knocking).
- Temporary Stabilization Loan: Kansas SHPO offers low-interest loans (3%) for urgent fixes while pursuing grants. (Not currently interested in a loan)

#### Recommendations:

- Short-Term (0-3 months): Secure SHPO nomination & small Culture Preservation Grant for repairs.
- Medium-Term (3-12 months): Target HTF/HEAL for full rehab; use AIP if airport safety angle.
- ROI: Highlight MAAM's role as Liberal's #1 attraction (12k+ visitors/year); restored hangar could add exhibits, boosting tourism revenue.
- Total Potential: Layering 2-3 sources could cover \$200k+ for repairs + exhibits.

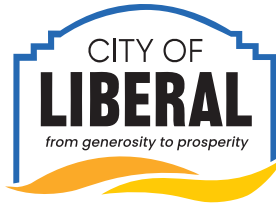

**CITY OF LIBERAL  
CITY COMMISSION MEETING  
December 9, 2025  
AGENDA ITEM # 6.**

To: Mayor Jose Lara  
Vice Mayor Matt Landry  
Commissioner Ron Warren  
Commissioner Janeth Vazquez  
Commissioner Jeff Parsons

Date: December 9, 2025

From: Scarlette Diseker, City Manager

RE: EOY Water Transfer

After consistent monitoring of the General Fund, City Staff are requesting an end-of-year transfer from the Water Utility Fund as allowed per K.S.A. 12-825d. We have maintained flat property tax dollars over the past three years with the intent of keeping mill levels stable; however, we have confirmed that a Water Transfer will be needed to meet year-end expenses and cash rollover expectations. Utility transfers are allowed with Commission approval. The last time we made a year-end Water Transfer was in 2021, so we have been able to build a healthy Water Fund over the past four years.

There is currently \$1,500,000 in remaining 2025 Water Utility Fund budget authority, so this will allow for the transfer of funds without a budget amendment.

**Recommendation:**

City Staff recommend Commission consideration for a Water Utility Transfer to the General Fund in the amount of \$1,100,000 per K.S.A. 12-825d.

<b>Transfer From</b>	<b>Transfer To</b>	<b>Description</b>	<b>Amount</b>
Water Utility Fund	General Fund	Reimburse 2025 Expenses	1,100,000.00



**CITY OF LIBERAL  
CITY COMMISSION MEETING  
December 9, 2025  
AGENDA ITEM #**

To: Mayor Jose Lara  
Vice Mayor Matt Landry  
Commissioner Ron Warren  
Commissioner Janeth Vazquez  
Commissioner Jeff Parsons

Date: December 9, 2025

From:

RE: ADJOURNMENT

**Recommendation:**